

**MiniZ is more  
than a loader,  
it is a proven  
concept.**

Thanks to constant innovations, we strive to be one step ahead at KOVACO ELECTRIC. We believe in the power of simplicity, which is why we have developed new types of 100% electric compact loaders. Powerful devices with up to 8 hours endurance on a single charge, zero negative impact on the environment, minimal maintenance costs and down time.



# Compact loader.

**MINI Z.** Compact and precisely manufactured electric loader represents the highest technology and years of experience of Kovaco Electric.

Battery life

**4-8<sub>h</sub>**

Dependant on use  
and load

Maximum lifting height

**2070<sub>mm</sub>**

Class Leading for  
extreme versatility

Load capacity

**400<sub>Kg</sub>**

Ultimate power in  
a small package





Extensive safety features

Ground breaking powertrain

Micro speed for precision maneuverability

Minimal maintenance

100% Eco-friendly

Compact Dimensions

**1150** height  
mm / **800** width  
mm

Fits through standard doorways

Remote control

**50** m

Safe, controlled ease of operation

Battery capacity

**10.8** kW

Full charge in under 5 hours

**Extreme power  
in compact  
design.**



**\*Fits through standard door.**

# Technical specifications.



SPECIFICATIONS	METRIC	IMPERIAL
Rated load capacity	400 kg	882 lb
Tipping load	800 kg	1 764 lb
Minimum travel speed	0,1 km/h	0,06 mph
Maximum travel speed	5 km/h	3,1 mph
Hinge Pin Height	2070 mm	81.5 in
Overall width	790 mm	31 in

ENGINE	METRIC	IMPERIAL
Engine type: electric	3xIPM120	3xIPM120
Maximum performance	3x2,7 kW	3x4 HP

## STANDARD FEATURES

- Basic Bucket
- Danfoss Professional ISO Joystick Remote Control
- Lead-Acid battery 48V/225Ah
- External Battery Charger (Nema 14-50)
- Operator Platform
- Danfoss Hydraulic system
- 3 independent motors – 2 for drive, 1 for Hydraulics
- Micro-speed Control

Compare technical specifications for this product online at [www.kovacoelectric.com](http://www.kovacoelectric.com)

**miniZ**

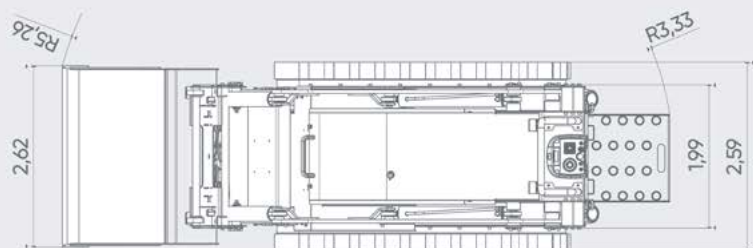
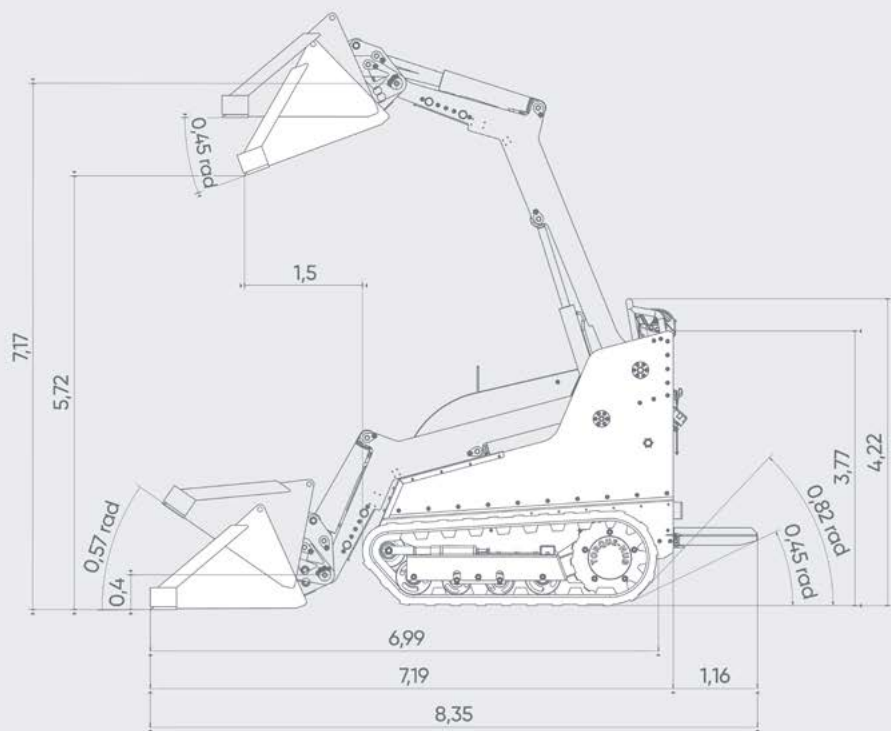

WEIGHTS	METRIC	IMPERIAL
Rated operating weight	1 100 kg	2 425 lb
Total weight of the loader	1 500 kg	3 307 lb

HYDRAULICS	METRIC	IMPERIAL
Hydraulic oil pressure	150 bar	2175,6 psi
Hydraulic oil flow	25 l/min	6,6 gal/min
Hydraulic oil reservoir	30 l	7,9 gal

**Professional remote control with reach of 50m.**



# With a wide range of attachments.



4:1 bucket



Forks with retainer



Grate shovel



Pallet forks



Bulk bucket



... plus 9 other attachments  
on [kovacoelectric.com](http://kovacoelectric.com)