



**T870** | Compact Loaders



**POWER**  
meets  
**COMFORT**  
**BY BOBCAT**



## Machine Rating

|                                       |               |
|---------------------------------------|---------------|
| Rated operating capacity              | 1508 kg       |
| Tipping load                          | 4306 kg       |
| Pump capacity                         | 90.1 L/min    |
| Pump capacity (with high flow option) | 141.6 L/min   |
| System relief at Quick Couplers       | 23.8–24.5 MPa |
| Max. travel speed — low range         | 10.5 km/h     |
| Max. travel speed — high range        | 18.3 km/h     |

## Engine

|                                   |                        |
|-----------------------------------|------------------------|
| Make / Model                      | Kubota / V3800-DI-T-E3 |
| Fuel / Cooling                    | Diesel / Liquid        |
| Power                             | 74 kW                  |
| Torque at 1600 RPM ( ISO9249 EEC) | 325 Nm                 |
| Number of cylinders               | 4                      |
| Displacement                      | 3800 cm <sup>3</sup>   |
| Fuel tank capacity                | 134.8 L                |

## Weights

|                  |         |
|------------------|---------|
| Operating weight | 5751 kg |
|------------------|---------|

## Controls

|                                 |   |
|---------------------------------|---|
| Vehicle steering                | Direction and speed controlled by two joysticks |
| Loader hydraulics tilt and lift | Selectable Joystick Control (SJC)               |
| Front auxiliary (standard)      | Electrical switch on right-hand joystick        |

## Drive System

|              |   |
|--------------|---|
| Transmission | Infinitely variable tandem hydrostatic piston pumps, driving two fully reversing hydrostatic motors |
|--------------|---|

## Standard Features

|   |  |
|---|--|
| Roller Suspension™                        | Work lights, front and rear                |
| Selectable Joystick Controls (SJC)        | Parking brake                              |
| Adjustable suspension seat                | Seat belt                                  |
| Automatically activated intake air heater | Seat bar                                   |
| Bob-Tach™ frame                           | Turbo-charger with approved spark arrestor |
| Bobcat Interlock Control System (BICS)    | Tracks — rubber — 450 mm — C-pattern       |
| Deluxe operator cab                       | CE certification                           |

Includes interior cab foam, side, top and rear windows, cab door with windshield wiper and sensor, cup holder, storage compartment and horn

### Instrumentation

### Lift arm support

\* Roll Over Protective Structure (ROPS) - meets requirements of SAE-J1040 and ISO 3471; Falling Object Protective Structure (FOPS) - meets requirements of SAE-J1043 and ISO 3449, Level I

## Options

|                         |                                |
|-------------------------|--------------------------------|
| Two speed               | Cab enclosure with heating     |
| Heavy duty radio        | High flow auxiliary hydraulics |
| Deluxe instrument panel | Air conditioning               |
| Power Bob-Tach™         |                                |

## Dimensions

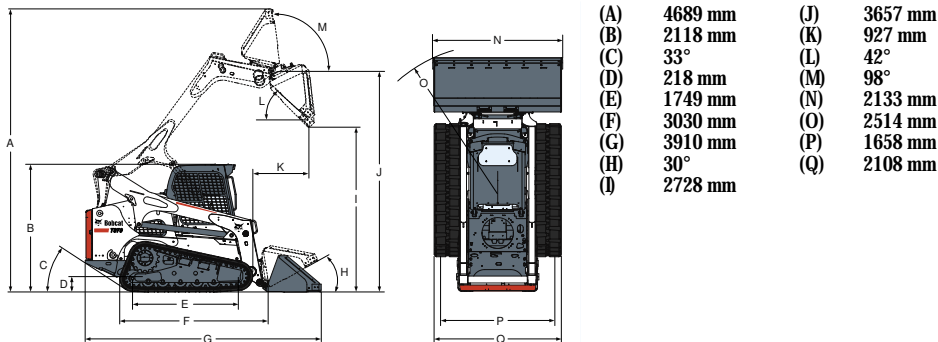

## Attachments

- Angle broom\*†
- Auger
- Bale forks
- Buckets
- Wood chipper\*
- Concrete pump\*
- Dozer blade\*
- Dumping hopper
- Flail cutter
- Forestry cutter
- Grader\*
- Hydraulic breaker\*\*
- Industrial grapple
- Mower
- Over-the-tyre tracks
- Pallet forks - standard
- Pallet forks - hydraulic
- Rear stabilizers
- Snow blower\*
- Sod layer\*
- Soil conditioner\*
- Spreader
- Stump grinder\*
- Super scraper
- Tree transplanter\*
- Trencher
- Utility frame
- Vibratory roller
- Water kit
- Wheel saw\*

\*Attachment control kit required.

\*\*When operating the loader with this attachment, a Special Applications Kit must be used.

†Optional water kit.



[www.bobcat.eu](http://www.bobcat.eu)