

ZAXIS-6 series

HITACHI

Reliable solutions

HIGH REACH DEMOLITION EXCAVATOR

A P P L I C A T I O N & A T T A C H M E N T



ZAXIS350LC

Model Code	ZX350LC-6
Engine Rated Power	210 kW (ISO14396)
Operating Weight	39 600 - 47 400 kg
Attachment Tool Weight	3 000 / 3 500 kg

ZX350LC-6

High reach demolition

NO COMPROMISE

The ZX350LC-6 high reach demolition excavator incorporates unique Hitachi technology that has been expertly developed for special applications. This innovative model has been created to deliver the highest level of performance, but without compromising on the increasing demand for operational efficiency within the demolition industry.

The result is the ultimate demolition machine, reinforcing Hitachi's reputation for the quality of its engineering and the durability of its products. The ZX350LC-6 is the epitome of reliability, with incredibly versatile features that highlight its suitability for a variety of challenging demolition sites.



6. THE ULTIMATE IN RELIABILITY



8. INDISPUTABLE DURABILITY



10. A VERSATILE PLAYER



DEMAND DURABILITY

The Hitachi ZX350LC-6 high reach demolition excavator has been developed using cutting-edge technology and decades of specialist industry experience. Perfectly suited to the demands of the European demolition sector, it has been built to deliver exceptional levels of durability and productivity.



Easy transportation

A dedicated stand for the front attachments is supplied to hold them firmly in place for transportation between sites.

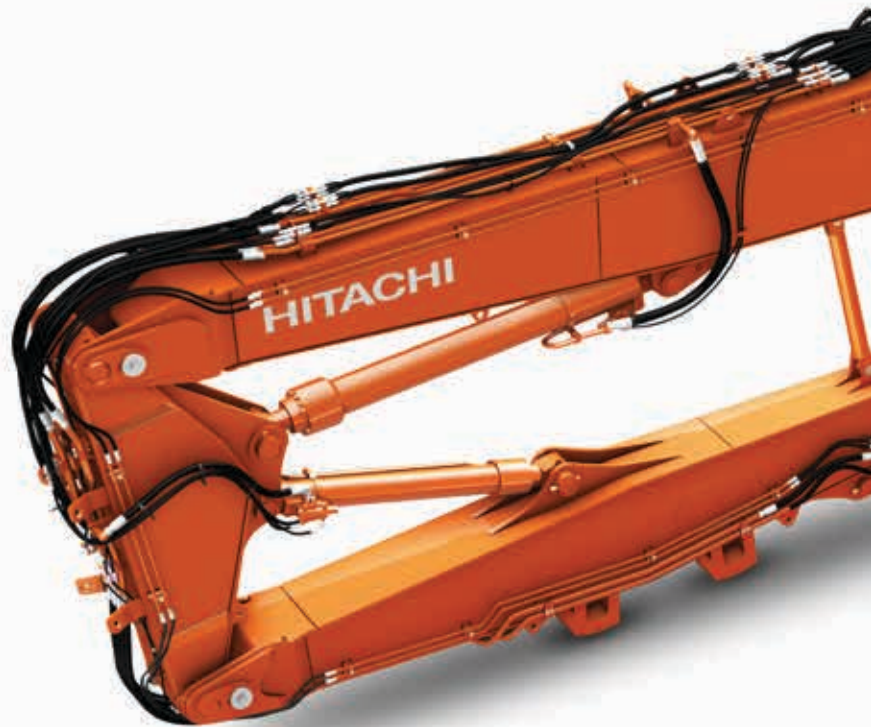

Added durability

The main frame has been reinforced with stronger and thicker materials, and a larger diameter boom bushing.



Saving time and money

The hydraulic connecting pins facilitate the easy and fast removal and installation of the different front attachments.



Safety through stability

As well as a 7.6-tonne counterweight, an additional 3.4-tonne option is supplied for high reach and two-piece boom work.





High reach flexibility

A 23-metre high reach arm allows for precise demolition work to be carried out on buildings up to a height of six or seven storeys.

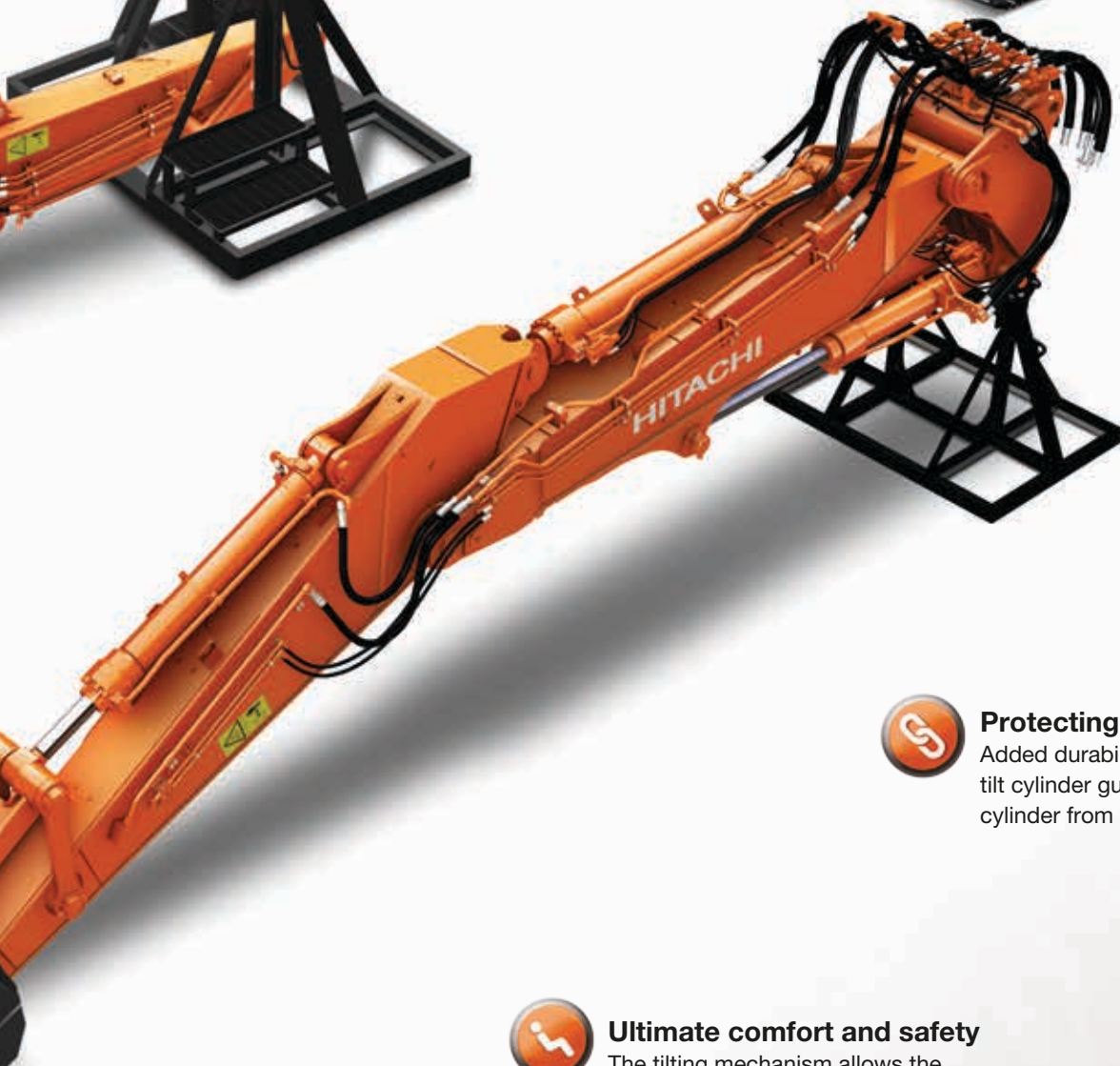

Protecting your investment

Added durability is provided by the tilt cylinder guard, which protects the cylinder from falling objects.



Ultimate comfort and safety

The tilting mechanism allows the operator to choose the best position for maximum visibility.



Added protection from the front guard.



Quick couplers enable faster changeovers.



The stability of an additional counterweight.

THE ULTIMATE IN RELIABILITY

Like all Hitachi Zaxis-6 special application machines, the ZX350LC-6 high reach demolition excavator is built for purpose to operate efficiently on the most challenging of job sites. It delivers optimum levels of availability and performance, and can be relied upon to deliver a profitable return on investment.

Safety comes first

The ZX350LC-6 has sturdy top and front OPG (Operator Protective Guards) that meet ISO safety standards. To allow for easy access cleaning, the top OPG can be opened, and the crossbars are aligned to ensure clear visibility. These features protect the operators and help avoid any unnecessary damage to the machine.

Optimum operational hours

The hydraulic connecting pins allow for the quick assembly and disassembly of the three front attachments, which helps to maximise operational hours. The device includes a hook and four connecting pins, and a position sensor ensures that the pins are connected safely and securely.

High-pressure couplers and lever-type quick couplers also contribute to a shorter changeover. The front attachment mode selector is displayed on the multi-function monitor, so you can quickly change the hydraulic circuit of the machine, according to the selected front attachment.

A stable base

The 7.6-tonne counterweight on the ZX350LC-6 is supplemented by an additional 3.4-tonne option for high reach and two-piece boom work for increased stability and productivity. It can be mounted quickly on to the machine using a small crane and a new-look design prevents the engine cover from being impeded for easier maintenance.

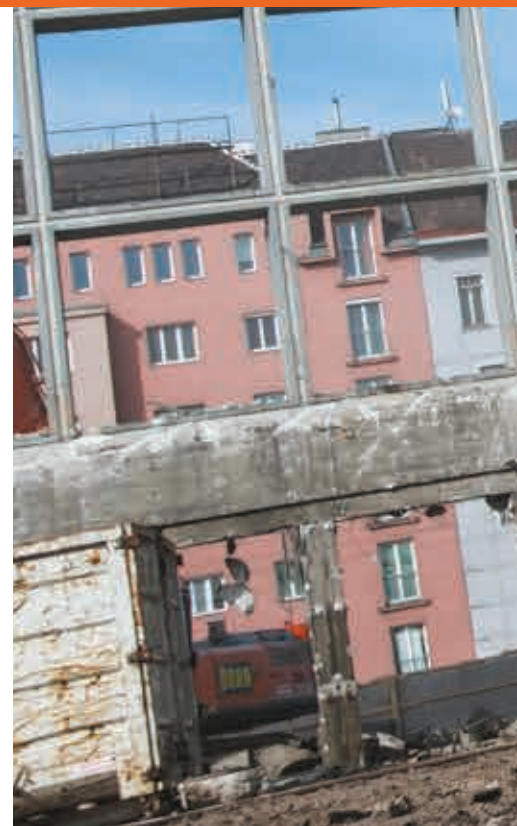





Guard protects the cylinder from potential damage.



The main frame is reinforced for greater durability.



INDISPUTABLE DURABILITY

With a market-leading reputation for the most reliable and durable special application machinery, Hitachi draws from more than four decades of experience of manufacturing mechanical and hydraulic excavators. The ZX350LC-6 high reach demolition model is the most recent incarnation of this expertise and has been developed to withstand the most demanding of working environments.



Minimal downtime thanks to durable covers.



Lower cost of ownership

Our main aim behind manufacturing durable high reach demolition machines was to lower the cost of ownership. The ZX350LC-6 incorporates several features designed to prevent damage and minimise downtime. For example, the tough metal tilt cylinder guard protects the cylinder from potential damage caused by falling objects.

Optimum availability

The Zaxis-6 machine's track and upper structure have also been reinforced with a series of other highly durable covers. They have been added to protect the hoses, piping and valves from obstacles

during the demolition process, and ensure the ZX350LC-6 maintains high levels of availability.

Reinforced main frame

The latest Hitachi high reach demolition machines have also been designed with stronger main frames, designed specifically for this application. These have been reinforced with stronger and thicker materials, and a larger diameter boom bushing.



An enhanced view with the tilted cab.



A pillarless window increases upward visibility.



The monitor shows swing angle and overload warnings.

A VERSATILE PLAYER

The flexibility of the ZX350LC-6 makes it a versatile player with three easily interchangeable front attachments, ideal for a wide range of high reach demolition projects. The special application machine is capable of providing a smooth, fast and precise operation, as well as high levels of productivity and fuel efficiency to complete each job on time and within budget.

A comfortable view

An enhanced view is extremely advantageous on challenging job sites, allowing operators to work accurately, while sitting in a comfortable position, and avoiding potential risks. This is possible on the ZX350LC-6 thanks to the smooth and efficient tilting mechanism, which tilts the cab to an angle of up to 30 degrees.

Clear visibility

The new Hitachi demolition excavator's cab has been designed with pillarless glass and a roof window wiper. These features increase upward visibility and give an uninterrupted view of high reach work. All of the windows are made of laminated safety glass and the front wipers have

been repositioned in parallel to the window, ensuring that it can be cleaned effectively.

Safety first

A swing angle alarm has been fitted to the new Hitachi high reach demolition machine. This highlights when the machine swings close to its limit and is approaching a potentially unstable position with an additional alert appearing on the monitor in the cab.

Another safety warning comes with the HRD overload warning system. When the machine inclines close to its limit, it shows the load ratio on the monitor by sensing the boom angle and pressure.





SPECIFICATIONS

ZAXIS 350LC

ENGINE

Model	Isuzu AQ-6HK1X
Type	4-cycle water-cooled, common rail direct injection
Aspiration	Variable geometry turbocharged, intercooled, cooled EGR
Aftertreatment	DOC and SCR system
No. of cylinders	6
Rated power	
ISO 14396	210 kW at 1 900 min ⁻¹
ISO 9249, net	202 kW at 1 900 min ⁻¹
SAE J1349, net	202 kW at 1 900 min ⁻¹
Maximum torque	1 080 Nm at 1 500 min ⁻¹
Piston displacement	7.790 L
Bore and stroke	115 mm x 125 mm
Batteries	2 x 12 V / 135 Ah

HYDRAULIC SYSTEM

Hydraulic Pumps

Main pumps	3 variable displacement axial piston pumps
Maximum oil flow	2 x 288 L/min 1 x 260 L/min
Pilot pump	1 gear pump
Maximum oil flow	36.4 L/min
Additional pump	1 gear pump
Maximum oil flow	30.0 L/min

Hydraulic Motors

Travel	2 variable displacement axial piston motors
Swing	1 axial piston motor

Relief Valve Settings

Implement circuit	34.3 MPa
Swing circuit	32.4 MPa
Travel circuit	34.3 MPa
Pilot circuit	3.9 MPa
Power boost	38.0 MPa

UPPERSTRUCTURE

Revolving Frame

D-section frame for resistance to deformation.

Swing Device

Axial piston motor with planetary reduction gear is bathed in oil. Swing circle is single-row. Swing parking brake is spring-set/hydraulic-released disc type.

Swing speed	9.7 min ⁻¹ (rpm)
Swing torque	120 kNm

Operator's Cab (High Reach Demolition Cab)

Independent spacious cab, 1 005 mm wide by 1 675 mm high, conforming to ISO* Standards.

* International Organization for Standardization

UNDERCARRIAGE

Tracks

Heat-treated connecting pins with dirt seals. Hydraulic (grease) track adjusters with shock-absorbing recoil springs.

Numbers of Rollers and Shoes on Each Side

Upper rollers	2
Lower rollers	8
Track shoes	48
Track guards	3

Travel Device

Each track driven by 2-speed axial piston motor. Parking brake is spring-set/hydraulic-released disc type. Automatic transmission system: High-Low.

Travel speeds	High : 0 to 5.0 km/h Low : 0 to 3.2 km/h
---------------------	---

Maximum traction force ... 298 kN

Gradeability

17% (10 degree) continuous

SOUND LEVEL

Sound level in cab according to ISO 6396 LpA 69 dB(A)
External sound level according to ISO 6395 and
EU Directive 2000/14/EC LwA 105 dB(A)

SERVICE REFILL CAPACITIES

Fuel tank	630.0 L
Engine coolant	43.0 L
Engine oil	48.0 L
Swing device	17.0 L
Travel device (each side)	9.2 L
Hydraulic system	340.0 L
Hydraulic oil tank	180.0 L
DEF/AdBlue® tank	70.0 L

WEIGHTS AND GROUND PRESSURE

High Reach Demolition 23 m

Equipped with attachment (attachment tool weight: 3 000 kg)

Shoe type	Shoe width	Operating weight	Ground pressure
Triple grouser	600 mm	47 400 kg	88 kPa

Demolition 2-Piece Boom

Equipped with attachment (attachment tool weight: 3 500 kg)

Shoe type	Shoe width	Operating weight	Ground pressure
Triple grouser	600 mm	46 800 kg	87 kPa

Demolition 2-Piece Boom

Equipped with 1.4 m³ bucket: 1 400 kg (ISO heaped)

Shoe type	Shoe width	Operating weight	Ground pressure
Triple grouser	600 mm	44 700 kg	83 kPa

Mono Block Boom

Equipped with attachment (attachment tool weight: 3 500 kg)

Shoe type	Shoe width	Operating weight	Ground pressure
Triple grouser	600 mm	41 700 kg	78 kPa

Mono Block Boom

Equipped with 1.4 m³ bucket: 1 400 kg (ISO heaped)

Shoe type	Shoe width	Operating weight	Ground pressure
Triple grouser	600 mm	39 600 kg	75 kPa

BACKHOE ATTACHMENT

Boom and arms are of all-welded, box-section design.

Bucket

Bucket types: 2-piece boom and mono block boom

Capacity	Width		No. of teeth	Weight
	Without side cutters	With side cutters		
1.4 m ³	1 275 mm	1 410 mm	5	1 400 kg

SPECIFICATIONS

DIMENSIONS (BASE MACHINE)

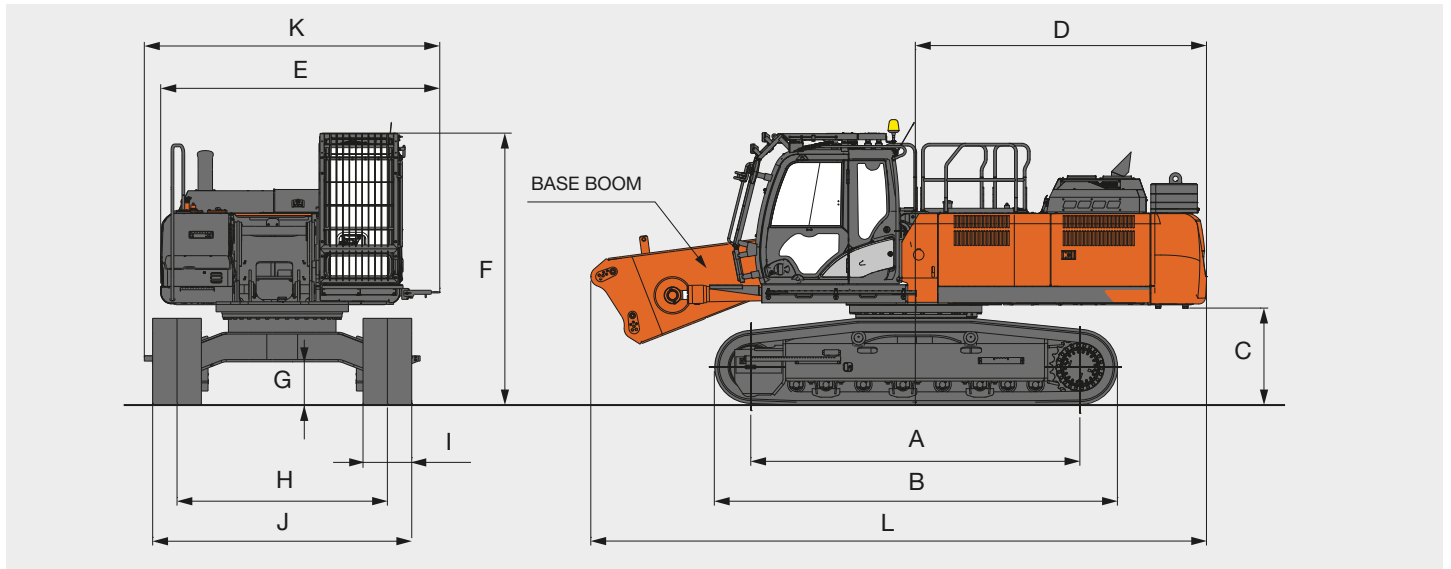

Unit: mm

A	Distance between tumbler	4 050
B	Undercarriage length	4 950
*1C	Counterweight clearance	1 160
D	Rear-end swing radius	3 600
E	Overall width of upperstructure	3 440
F	Overall height of cab	3 350
*1G	Min. ground clearance	500
H	Track gauge	2 590
I	Track shoe width	G 600
J	Undercarriage width	3 190
K	Overall width	3 640
L	Overall length	7 600
*2	Transportation weight	33 800 kg

*1 Excluding track shoe lug *2 Excluding counterweight G: Triple grouser shoe

WORKING RANGES

High Reach Demolition 23 m

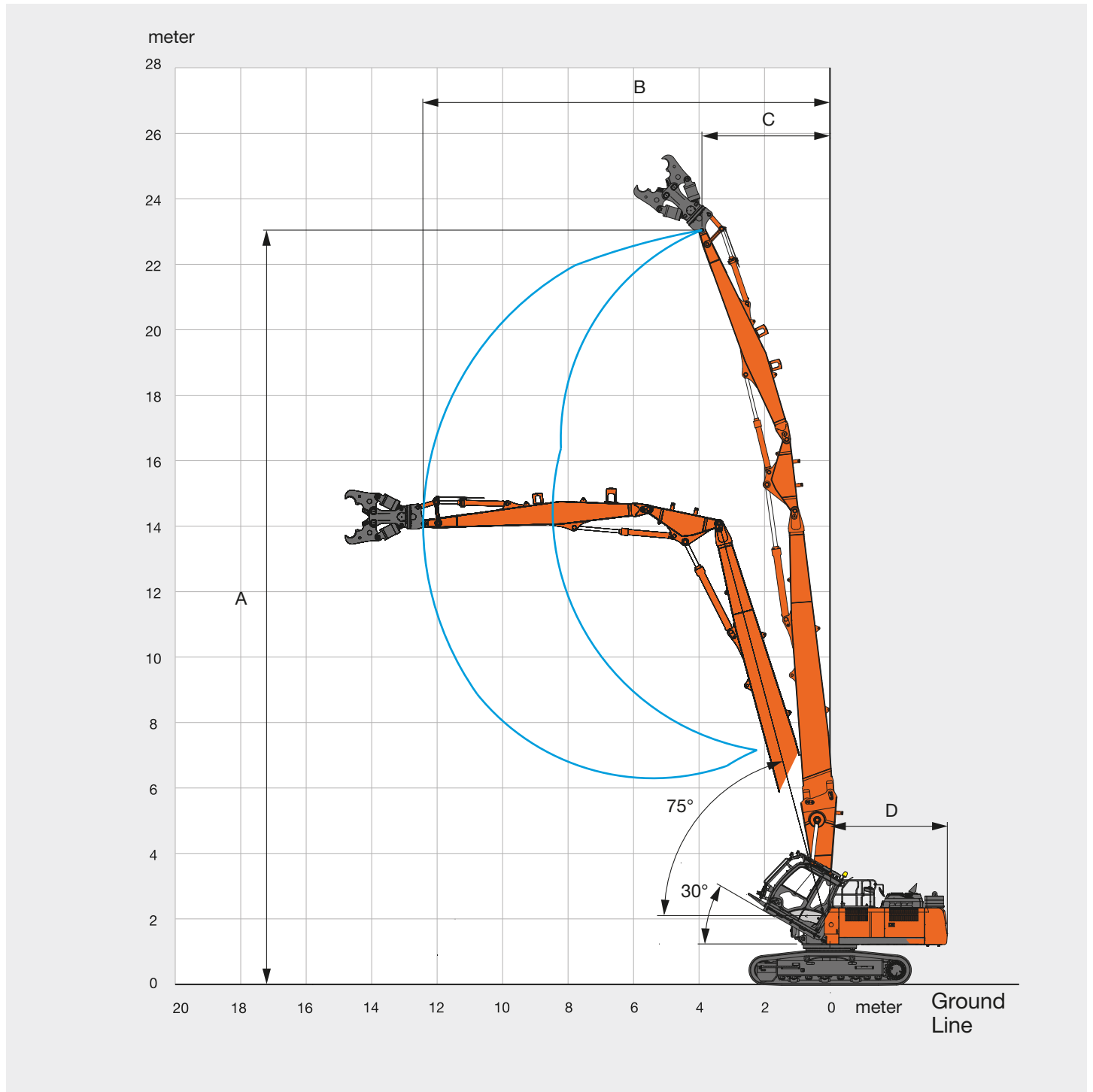

Unit: mm

High Reach Demolition 23 m	
A Max. working height (arm top point)	23 040
B Forward limited working reach (arm top point)	12 420
C Reach at max. height (arm top point)	3 910
D Rear-end swing radius	3 600
*Max. tool weight	3 000 kg

*Including quick hitch

SPECIFICATIONS

WORKING RANGES

Demolition 2-Piece Boom

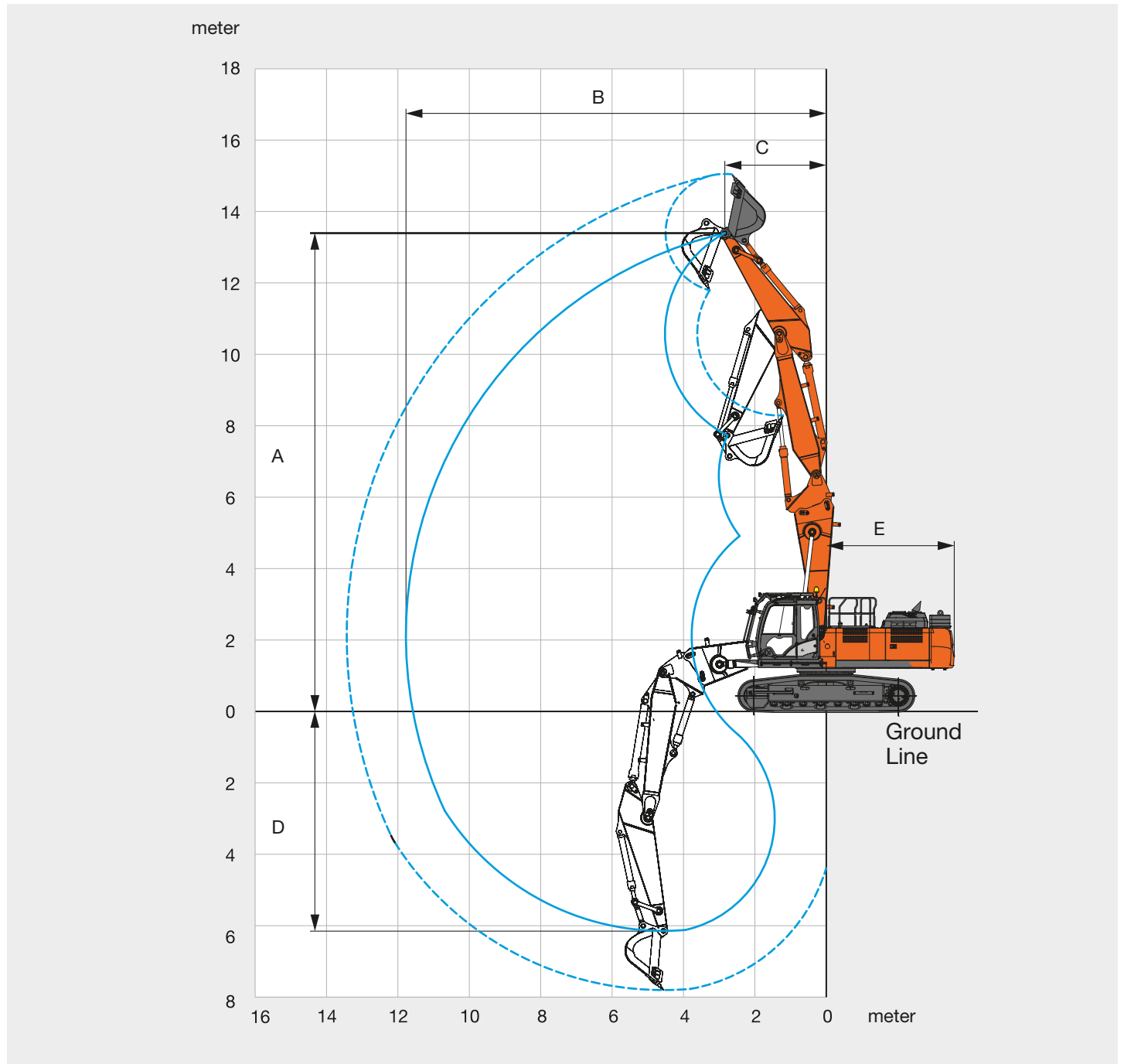

Unit: mm

	Demolition 2-Piece Boom
A Max. working height (arm top point)	13 390
B Max. working reach (arm top point)	11 770
C Reach at max. height (arm top point)	2 850
D Max. working depth (arm top point)	6 150
E Rear-end swing radius	3 600
*Max. tool weight	3 500 kg

*Including quick hitch

WORKING RANGES

Mono Block Boom

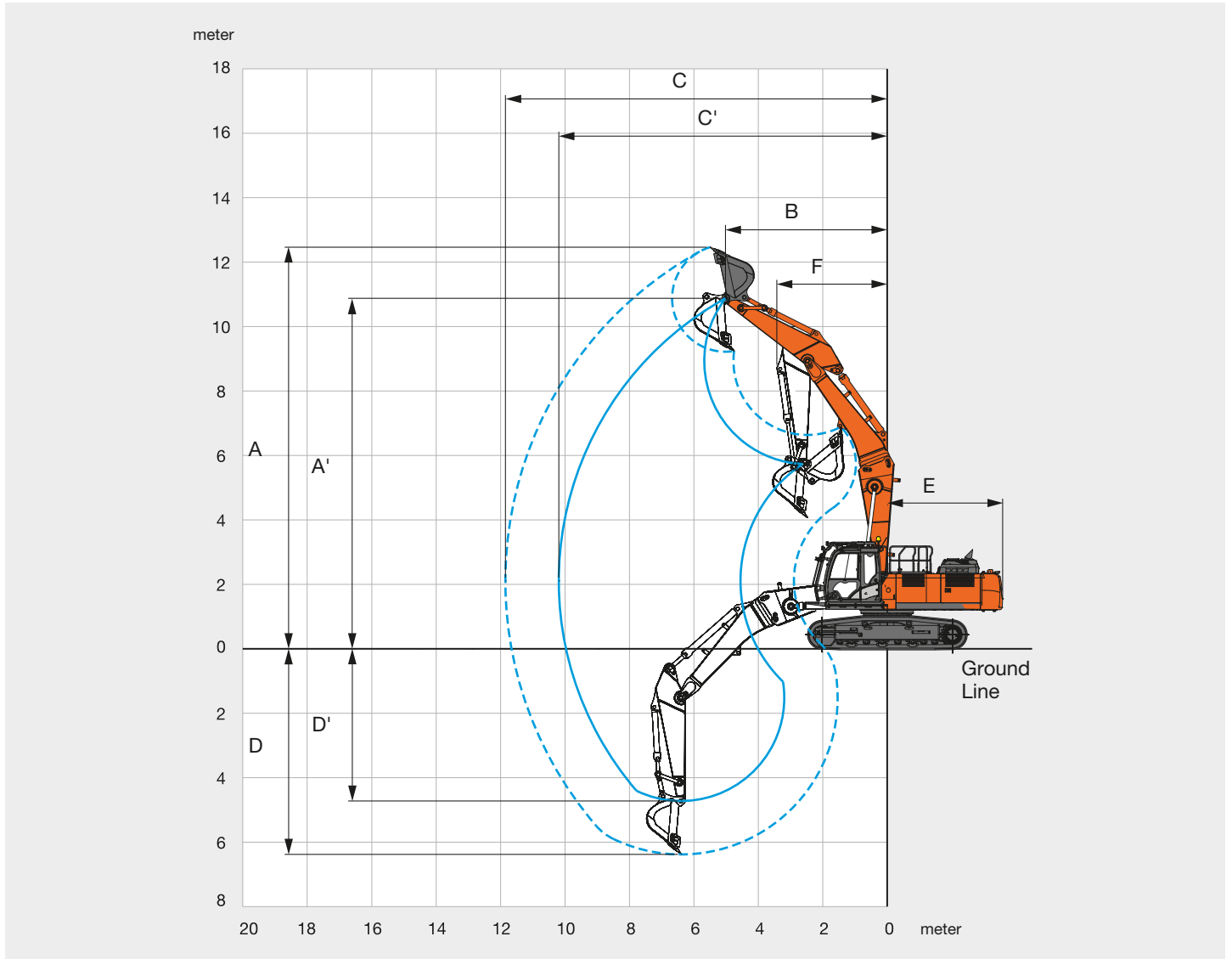

Unit: mm

	Mono Block Boom
A Max. digging height (bucket)	12 460
A' Max. working height (arm top point)	10 870
B Reach at max. height (arm top point)	5 030
C Max. digging reach (bucket)	11 840
C' Max. working reach (arm top point)	10 190
D Max. digging depth (bucket)	6 370
D' Max. working depth (arm top point)	4 720
E Rear-end swing radius	3 600
F Min. swing radius (bucket)	3 430
Bucket digging force ISO	246 kN
Arm crowd force ISO	185 kN
*Max. tool weight	3 500 kg

*Including quick hitch

SPECIFICATIONS

Metric measure

Notes: 1. Ratings are based on ISO 10567.

2. Lifting capacity of the ZAXIS Series does not exceed 75% of tipping load with the machine on firm, level ground or 87% of full hydraulic capacity.

3. The load point is the center line of the bucket pivot mounting pin on the arm.

4. *Indicates load limited by hydraulic capacity.

5. 0 m = Ground.

For lifting capacities, subtract bucket and quick hitch weight from lifting capacities.

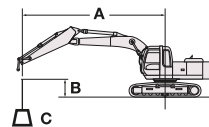

A: Load radius

B: Load point height

C: Lifting capacity

Demolition 2-Piece Boom



Unit : kg

Conditions	Load point height m	Load radius m												At max.reach		
		3.0		4.5		6.0		7.5		9.0		10.5		meter		
Arm: 3.2 m	12.0			*11 800	*11 800	*9 730	*9 730							*9 870	*9 870	6.24
Shoe: 600 mm	10.5			*10 100	*10 100	*9 650	*9 650	*7 880	*7 880					*8 290	7 620	8.19
Counterweight: 11 400 kg	9.0			*9 110	*9 110	*9 630	*9 630	*7 260	*7 260	*7 300	6 520			*7 550	5 770	9.51
	7.5	*9 070	*9 070	*10 700	*10 700	*9 390	*9 390	*7 160	*7 160	*7 150	6 440	*7 170	4 760	*7 170	4 760	10.5
	6.0	*18 600	*18 600	*12 800	*12 800	*9 170	*9 170	*7 510	*7 510	*7 250	6 170	*7 050	4 680	6 590	4 160	11.1
	4.5	*9 350	*9 350	*9 120	*9 120	*9 640	*9 640	*8 280	7 650	*7 610	5 830	7 150	4 520	6 090	3 790	11.5
	3.0			*5 630	*5 630	*8 650	*8 650	*9 230	7 060	*8 100	5 480	6 950	4 340	5 820	3 590	11.7
	1.5			*5 160	*5 160	*6 530	*6 530	*10 200	6 630	8 470	5 210	6 780	4 180	5 750	3 520	11.8
	0 (Ground)			*5 190	*5 190	*7 750	*7 750	*9 970	6 420	*8 250	5 040	6 680	4 080	*5 360	3 590	11.6
	-1.5	*9 180	*9 180	*6 350	*6 350	*9 760	8 800	*8 780	6 390	*7 330	4 990	*5 780	4 080	*4 710	3 800	11.2
	-3.0	*14 700	*14 700	*11 700	*11 700	*8 300	*8 300	*7 540	6 500	*6 240	5 080	*4 270	4 240	*4 270	4 240	10.5
	-4.5	*19 600	*19 600	*12 000	*12 000	*8 490	*8 490	*7 220	6 760	*5 430	5 360			*5 240	*5 240	9.12
	-6.0			*12 700	*12 700									*9 250	*9 250	5.89

Mono Block Boom

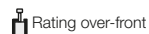

Unit : kg

Conditions	Load point height m	Load radius m								At max.reach		
		4.5		6.0		7.5		9.0		meter		
H-arm: 3.2 m	9.0			*10 400	*10 400					*6 670	*6 670	7.46
Shoe: 600 mm	7.5			*10 800	*10 800	*9 830	7 570			*6 300	5 820	8.63
Counterweight: 7 600 kg	6.0	*14 600	*14 600	*11 800	10 500	*10 200	7 320	8 430	5 330	*6 190	4 870	9.42
	4.5	*17 700	14 900	*13 300	9 750	*10 900	6 930	8 240	5 150	*6 280	4 320	9.91
	3.0	*12 500	*12 500	*14 700	8 920	10 600	6 500	7 990	4 920	*6 530	4 010	10.2
	1.5			14 200	8 260	10 200	6 110	7 750	4 700	6 430	3 890	10.2
	0 (Ground)	*11 700	*11 700	13 800	7 900	9 870	5 850	7 580	4 540	6 540	3 930	9.97
	-1.5	*17 400	11 900	13 600	7 770	9 730	5 720	7 510	4 480	6 950	4 160	9.52
	-3.0	*16 500	12 100	*13 400	7 830	9 760	5 750			7 840	4 690	8.79

TRANSPORTATION

COUNTERWEIGHT

Counterweight

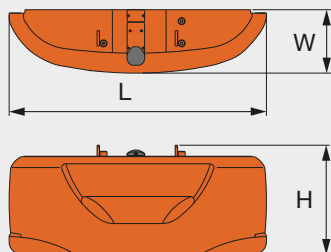

Counterweight

L: Length	mm	2 950
H: Height	mm	1 260
W: Width	mm	730
Weight	kg	7 600

Additional counterweight

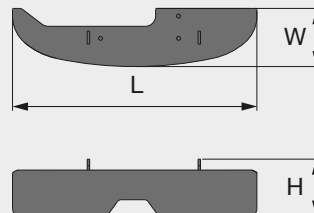

Additional counterweight

L: Length	mm	2 780
H: Height	mm	490
W: Width	mm	580
Weight	kg	3 430

FRONT ATTACHMENT

High reach demolition 23 m

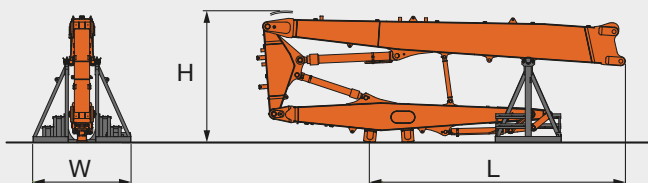

High reach demolition 23 m

L: Length	mm	9 250
H: Height	mm	3 320
W: Width	mm	2 450
Stand weight	kg	625
Total weight (with stand)	kg	7 890
Total weight (without stand)	kg	7 270

Demolition 2-piece boom

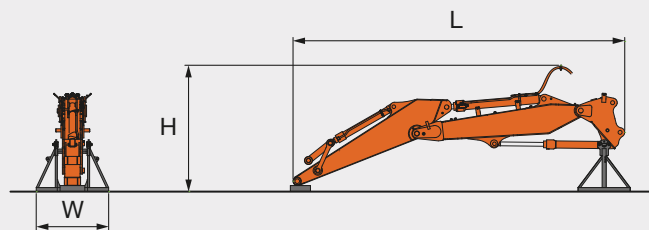

Demolition 2-piece boom

L: Length	mm	8 390
H: Height	mm	2 470
W: Width	mm	1 800
Stand weight	kg	240
Total weight (with stand)	kg	6 330
Total weight (without stand)	kg	6 090

Mono block boom

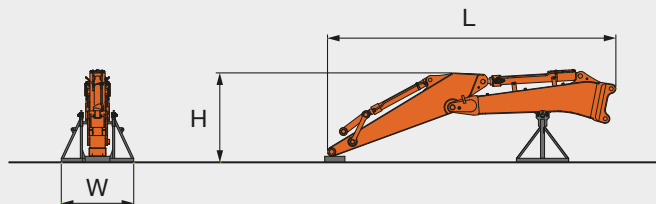

Mono block boom

L: Length	mm	7 130
H: Height	mm	2 330
W: Width	mm	1 800
Stand weight	kg	260
Total weight (with stand)	kg	4 710
Total weight (without stand)	kg	4 450

OVERALL

High reach demolition 23 m

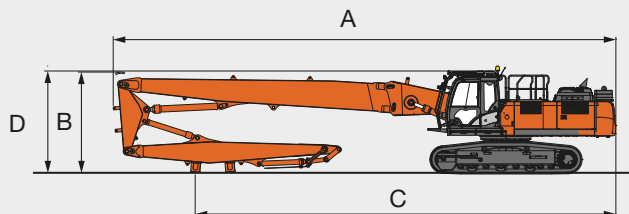

Unit: mm

High reach demolition 23 m

A Transport length	16 400
*B Overall height of front	3 310
C Length on ground	13 490
*D Overall height	3 520

*Including track shoe lug

Demolition 2-piece boom

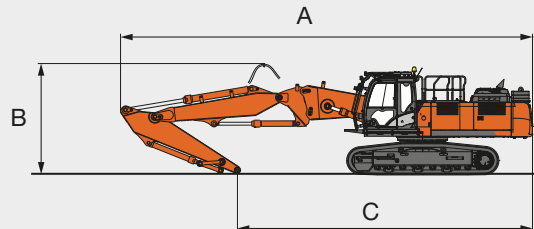

Unit: mm

Demolition 2-piece boom

A Transport length	13 440
*B Overall height (front)	3 630
C Length on ground	9 630

*Including track shoe lug

Mono block boom

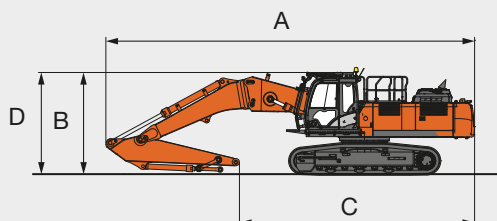

Unit: mm

Mono block boom

A Transport length	12 030
*B Overall height of front	3 280
C Length on ground	7 750
*D Overall height	3 520

*Including track shoe lug

EQUIPMENT

●Standard equipment ○Optional equipment

ENGINE	
Aftertreatment device	●
Air cleaner double filters	●
Alternator 50 A	●
Auto idle system	●
Auto shut-down control	●
Cartridge-type engine oil filter	●
Cartridge-type fuel main filter	●
Cold fuel resistance valve	●
DEF/AdBlue® tank inlet strainer and extension filler	●
DEF/AdBlue® tank with ISO magnet adapter	●
Dry-type air filter with evacuator valve (with Air filter restriction indicator)	●
Dust-proof indoor net	●
ECO/PWR mode control	●
Electrical fuel feed pump	●
Engine oil drain coupler	●
Expansion tank	●
Fan guard	●
Fuel cooler	●
Fuel pre-filter with water separator	●
Isolation-mounted engine	●
Maintenance free pre-cleaner	○
Radiator, oil cooler and intercooler	●

HYDRAULIC SYSTEM	
Accessories for breaker	●
Accessories for breaker & crusher	●
Accessories for 2 speed selector	●
Additional pump (30 L/min)	●
Auto power lift	●
Boom mode selector system	●
Control valve with main relief valve	●
High mesh full flow filter with restriction indicator	●
Hose rupture valve for arm	●
Hose rupture valve for boom	●
Pilot accumulator	●
Pilot filter	●
Power boost	●
Suction filter	●
Swing dampener valve	●
Two extra port for control valve	●
Variable hydraulic fan for oil cooler	●
Variable relief valve for breaker & crusher	●
Work mode selector	●

CAB	
All-weather sound suppressed steel cab	●
AM-FM radio	●
Ashtray	●
Auto control air conditioner	●
AUX. function lever (Breaker assist)	●
AUX. terminal and storage	●
Cigarette lighter 24 V	●
Demolition cab :	
FOPS for excavators compliant cab	●
Intermittent windshield wiper (Parallel type)	●
Laminated round glass (Green color) front window	●
Left side windows can be opened	●
OPG top guard fitted Level II (ISO10262)	●
OPG front guard fitted Level II (ISO10262)	●
Pillar-less front window	●
Roof window with wiper and washer	●
Drink holder with hot & cool function	●
Electric double horn	●
Engine shut-off switch	●
Evacuation hammer	●
Fire extinguisher bracket	○
Floor mat	●
Front window washer	●
Glove compartment	●
Hot & cool box	●
Intermittent windshield wipers	●
Key cylinder light	●
LED room light with door courtesy	●
Pilot control shut-off lever	●
Power outlet 12 V	○
Rear tray	●
Retractable seat belt	●
Rubber radio antenna	●
Seat : air suspension seat with heater	●
Seat adjustment part : backrest, armrest, height and angle, slide forward / back	●
Short wrist control levers	●
Sun visor (Front window/side window)	○
Tilting cab	●
Transparent roof with slide curtain	●
2 speakers	●
6 fluid-filled elastic mounts	●

MONITOR SYSTEM	
Alarms:	
overheat, engine warning, engine oil pressure, alternator, minimum fuel level, hydraulic filter restriction, air filter restriction, work mode, overload, SCR system trouble, etc	●
Alarm buzzers:	
overheat, engine oil pressure, overload, boom angle, swing angle, tilting cab	●
Display of meters:	
water temperature, hour, fuel rate, clock, DEF/AdBlue® rate	●
Other displays:	
work mode, autoidle, glow, rearview monitor, operating conditions, etc	●
Side view monitor	●
32 languages selection	●

LIGHTS	
Additional cab roof rear lights	●
Additional working light (Boom right side)	●
Rotating lamp	●
2 cab lights	●
2 working lights	●

UPPER STRUCTURE	
Batteries 2 x 135 Ah	●
Battery disconnect switch	●
Body top handrail	●
Counterweight :	
7 600 kg (Mono block boom)	●
11 000 kg (7 600 kg standard + 3 400kg additional)	●
High reach demolition and 2-piece boom	●
Electric fuel refilling pump with auto stop and filter	●
Fuel level float	●
Hydraulic oil level gauge	●
Lockable fuel refilling cap	●
Lockable machine covers	●
Lockable tool box	●
Platform handrail	●
Rear view camera	●
Rear view mirrors (Right & left side)	●
Side view camera	●
Skid-resistant plates and handrails	●
Swing parking brake	●
Utility space	●
6.0 mm thickness undercover	●

UNDERCARRIAGE	
Bolt-on sprocket	●
Reinforced track links with pin seals	●
Shoe: 600 mm triple grouser	●
Track undercover	●
Travel direction mark on track frame	●
Travel motor covers	●
Travel parking brake	●
Upper and lower rollers	●
3 track guards (Each side) and hydraulic track adjuster	●
4 tie down hooks	●

FRONT ATTACHMENTS	
Centralized lubrication system	●
Damage prevention plate and square bars (Backhoe arm)	●
Dirt seal on all bucket pins	●
Hose rupture valves	●
Storage stand : High reach demolition	
Mono block boom	●
2-Piece boom	●
Tilt cylinder guard (High reach demolition)	●
Welded bucket link A (High reach demolition)	●
Welded bucket link A (2-Piece boom / mono block boom)	●
1.4 m³ (ISO heaped) rock bucket (with Dual type side shrouds)	○

MISCELLANEOUS	
Global e-Service	●
Onboard information controller	●
Standard tool kit	●





Prior to operating this machine, including satellite communication system, in a country other than a country of its intended use, it may be necessary to make modifications to it so that it complies with the local regulatory standards (including safety standards) and legal requirements of that particular country. Please do not export or operate this machine outside the country of its intended use until such compliance has been confirmed. Please contact your Hitachi dealer in case of questions about compliance.

These specifications are subject to change without notice. Illustrations and photos show the standard models, and may or may not include optional equipment, accessories, and all standard equipment with some differences in color and features. Before use, read and understand the Operator's Manual for proper operation.

